

MODEL 255 Specifications

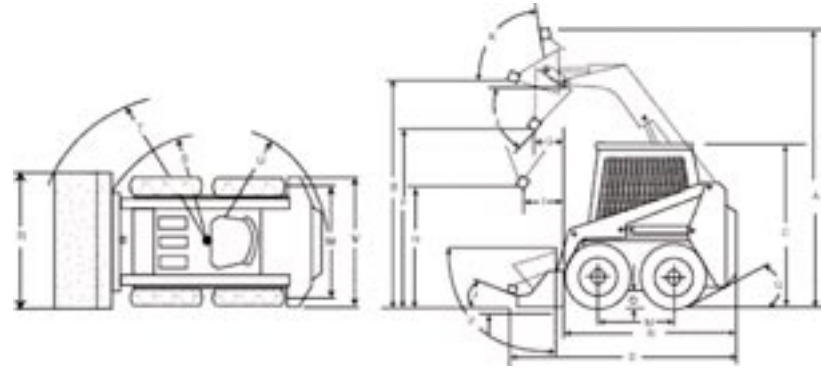

Performance

Operating Capacity, kg (lbs)	1134 (2500)
Operating Cap.w/Optional Counterweight, kg (lbs)	1179 (2600)
Tipping Load, kg (lbs)	2268 (5000)
Travel Speed, Low Range, km/hr (mph)	10.9 (6.8)
Travel Speed, High Range, km/hr (mph)	19.8 (12.3)
Hydraulic Pump Output, l/m (gpm)	79.5 (21.0)
Breakout Force, kg (lbs)	3175 (7000)
Shipping Weight, kg (lbs)	3357 (7400)
Operating Weight, kg (lbs)	3629 (8000)

Engine

Make	Kubota
Model	V3300T Turbo
Power, ISO net kw (net hp), [gross hp]	61.9 (83) [87.4]
Torque, kg/m (ft.lbs)	28.4 (205)
Displacement, cc (cu. in.)	3318 (202.5)
No. Cylinders	4
Rated Engine Speed, rpm	2750
Cooling System	Liquid
Fuel Type	Diesel No. 2
Fuel Capacity, l (gal)	109 (28.7)
Engine to Pump Connection	Direct Coupling

Electrical

Ignition	12 Volt
Battery, CCA	1460
Alternator, amps	60
Remote Boosting Terminal Standard	Yes

Controls/Drive System

Steering Controls	Two Hand Levers
Hydraulic Controls	Two Hand Levers or Two Foot Pedals
Transmission	Hydrostatic
Drive Chain Size	No. 100 H

Hydraulics

Hydraulic Pump Output, l/m (gpm)	79.5 (21.0)
High Flow Output (opt.), l/m (gpm)	151.4 (40)
System Relief pressure, bar (psi)	206.8 (3000)
Number of Bucket Cylinders	2
Breakout Force, kg (lbs)	3175 (7000)
Boom Mounted Aux. Hydraulics Std.	Yes
Filtration	5 micron
Hydraulic Reservoir Capacity, l (gal)	133 (35)

Operator Comfort & Safety

Low Cab Sound Levels	Yes
Seat Bar Activated Parking Brake	Yes
Work Lights Standard	Yes
ROPS/FOPS Cab	Yes
Protective Seat Bar	Yes
Seat Belt	Yes
Hydraulic Controls Lock (seat, seat belt & seat bar sensors)	Yes
Cab Operated Boom Supports	Yes
Rear Window Glass Standard	Yes
Top Window Glass Standard	Yes
Loader Transport Tie Downs	Yes

Dimensional Specifications

A. Overall Operating Height, mm (in)	3988 (157)
B. Height to Hinge Pin, mm (in)	3143 (123.8)
C. Overall Height of Vehicle, mm (in)	2134 (84)
D. Overall Length with Bucket, mm (in)	3708 (146)
E. Dump Angle, Degree	36
F. Dump Height, mm (in)	2457 (96.8)
G. Reach- Fully Raised, mm (in)	546 (21.5)
H. Height at 45 deg. Dump Angle, mm (in)	2038 (80.3)
I. Reach at 45 deg. Dump Angle, mm (in)	641 (25.3)
J. Maximum Rollback at Ground, Deg.	20
K. Maximum Rollback Fully Raised, Deg.	87
M. Wheelbase, mm (in)	1238 (48.75)
N. Overall Length Less Bucket, mm (in)	2985 (117.5)
O. Ground Clearance, mm (in)	229 (9)
P. Maximum Grading Angle Bucket, Deg.	88
Q. Angle of Departure, deg.	27
R. Bucket Width, mm (in)	1854 (73)
S. Clearance Front-Less Bucket, mm (in)	1377 (54.2)
T. Clearance Front-With Bucket, mm (in)	2134 (84)
U. Clearance Circle Rear, mm (in)	1773 (69.8)
V. Overall Width - Less Bucket, mm (in)	1797 (70.8)
W. Tread, mm (in)	1486 (58.5)

Note: All dimensions are with 12.00 x 16.5 tires and 1854 mm (73 in) bucket.

SPECIFICATIONS AND DESIGN ARE SUBJECT TO CHANGE WITHOUT NOTICE. SPECIFICATIONS MAY VARY DEPENDING ON COUNTRY.



Maximum Power

255	Operating Capacity, kg (lb)	1134 (2500)
	HP Net, kw (hp)	61.9 (83)
	HP Gross, kw (hp)	65.2 (87.4)
	Hyd. Pump Output, l/m (gpm)	79.5 (21.0)
	High Flow Hyd. (Optional), l/m (gpm)	151.4 (40)
	Breakout Force, kg (lb)	3175 (7000)
	Two Speed Transmission (Optional)	
	Standard 5-year warranty	

P.O. Box 510 | 29 Hawkins Road | Centreville, New Brunswick | Canada E7K 3G4

P.O. Box 336 | Mars Hill, Maine | USA 04758

Tel: 506-276-4511 | Fax: 506-276-4308 | www.thomasloaders.com

1-866-BE TOUGH www.thomasloaders.com



A tough act to follow

The Thomas Model 255 has the power, performance and versatility to get your work done – fast! Power begins with its forceful 87.4 hp (65.2 kw) Kubota turbocharged diesel engine that just keeps on going. No matter how hard the digging conditions, the oversized hydraulic cylinders, combined with high boom and bucket breakout forces, let you easily dig into your work. Combine this brute power with the loader's shift on the go two speed option that gives you travel speeds of up to 12.3 mph (19.8 k/h) and you'll have quick cycle times for outstanding productivity.

- 2500 lb. (1134 kg) lift capacity – 2600 lb. (1179 kg) with optional counterweight.
- High output 87.4 HP (65.2 kw) Kubota turbocharged diesel.
- Wide 48.75 in. (1238 mm) wheelbase provides smooth, stable, flat-footed performance.
- Powerful, over 7000 lb. (3175 kg) of breakout force means easy bucket loading.
- Fast, over 12.3 mph (19.8 k/h) with optional two-speed.

255

Pick your job.

No matter what the job, Thomas has the right attachment to get it done quickly and efficiently. See your Thomas dealer for these and other available attachments.

At your service.

The Model 255 is designed to minimize maintenance, with new features that will help reduce downtime and make servicing easier. A wide opening, lockable rear door and swing out radiator provide total unobstructed service access. The job is tough, but Thomas can take the heat. The Model 255 is equipped with a high efficiency hydraulic oil cooler and massive 35 gal. (133 L) hydraulic tank, that's over 400% more volume than some competitive units. Both features are designed to reduce heat, helping you keep your cool and get maximum performance and life out of the hydraulic components. Power is transferred from the engine to the loader's drive system through a direct coupling which requires no regular adjustments or service. In addition, the loader's heavy-duty chain drive and integrated spring applied hydraulic release braking system are maintenance free. It all adds up to you spending more time on the job and less on maintenance.

Rugged to the core.

The Model 255 is also built stronger and tougher than other skid steer loaders in its class. Built-in survivability features include a main frame constructed of heavy wall, high tensile, structural steel tubing instead of bent steel sheets found on most competitive units. This provides a stronger more rigid frame to maintain long-term structural integrity. Massive 3 in. (76 mm) cylinders, large diameter hinge pins and heavy wall boom arms that are as much as 50% thicker are all features that help the Model 255 to stand up to high impact loading day after day. That's why every Thomas comes with the best customer protection plan in the industry, a full 5-year, 5000-hour warranty*. Coverage includes a 3-year, 3000-hour full machine and an additional 2-year, 2000-hour power train warranty. Thomas recognizes that these are more than machines, they're investments, and we're dedicated to building them to last.

* Available in United States, Canada and Australia. All other countries are provided a 1-year full machine, 2-year engine and 5-year main frame warranty.

Buckets

Choose from a variety of bucket options to meet the demands of your material handling needs.



Angle Broom

Keep your site clean of dirt or other debris with the Thomas angle broom.



4 in 1 Bucket

Dig, push, drag or grab your work. The Thomas 4 in 1 bucket does it all.



Grapple Bucket

Handle large bulky loads with ease with the Thomas heavy-duty industrial grapple bucket.



Auger

Dig holes for fence posts or trees in the toughest conditions easily and accurately.



Dozer Blade

Push the work around with the tough and versatile Thomas hydraulic dozer blade.



Trencher

Dig trenches for laying cable or pipe quickly and efficiently.



Spreader

Spread sand or salt on driveways, sidewalks or parking lots to help control ice.



Vibratory Roller

These heavy-duty rollers make easy work of asphalt patchwork or any of your compaction needs.



Power Landscape Rake

For leveling, spreading and site preparation, the power landscape rake will get the job done.



Hydraulic Breaker

Break through concrete and other tough surfaces with the Thomas hydraulic breaker.



Pallet Forks

Handle palletized loads with ease with durable Thomas pallet forks.



Some equipment shown may be optional.